

XB-838 直立機械裝配

A. 直立機械

1. 完成圖

完成圖

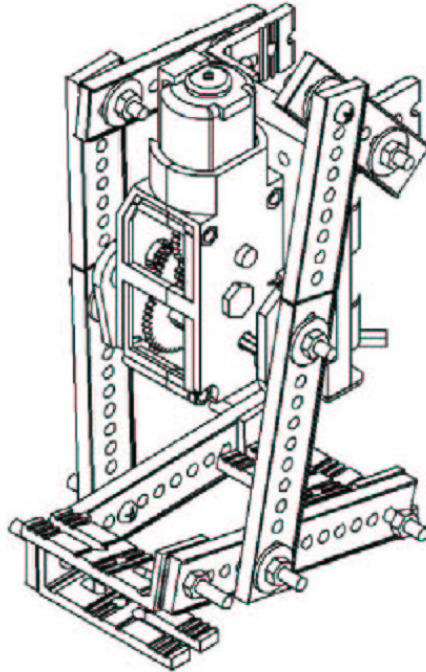

2. 底板尺寸圖

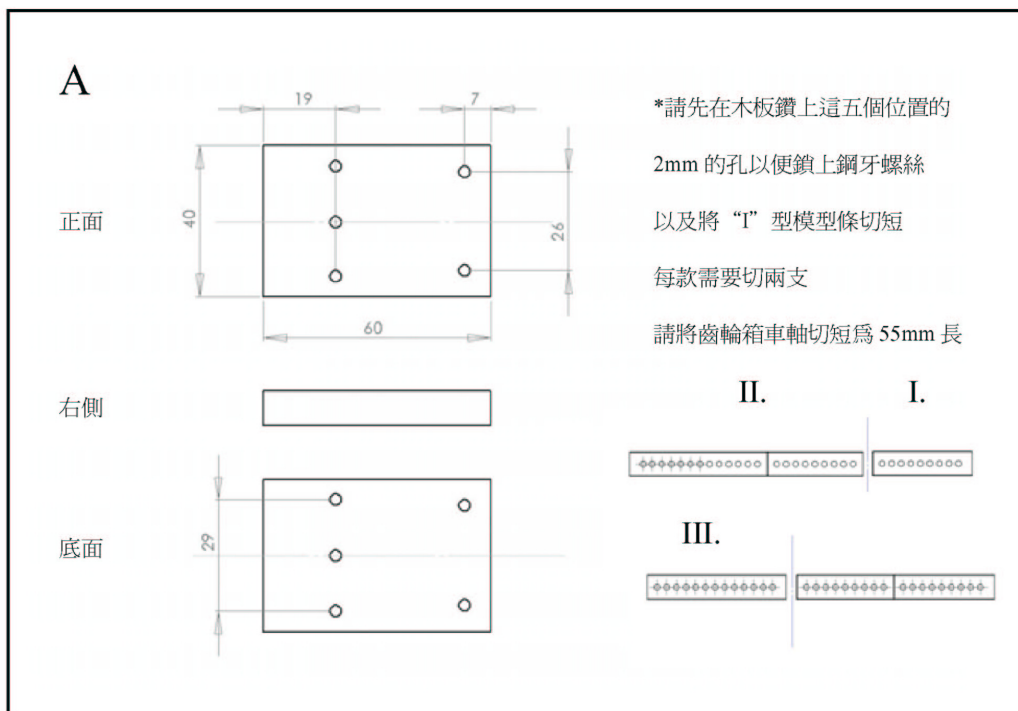

3. 裝配全圖

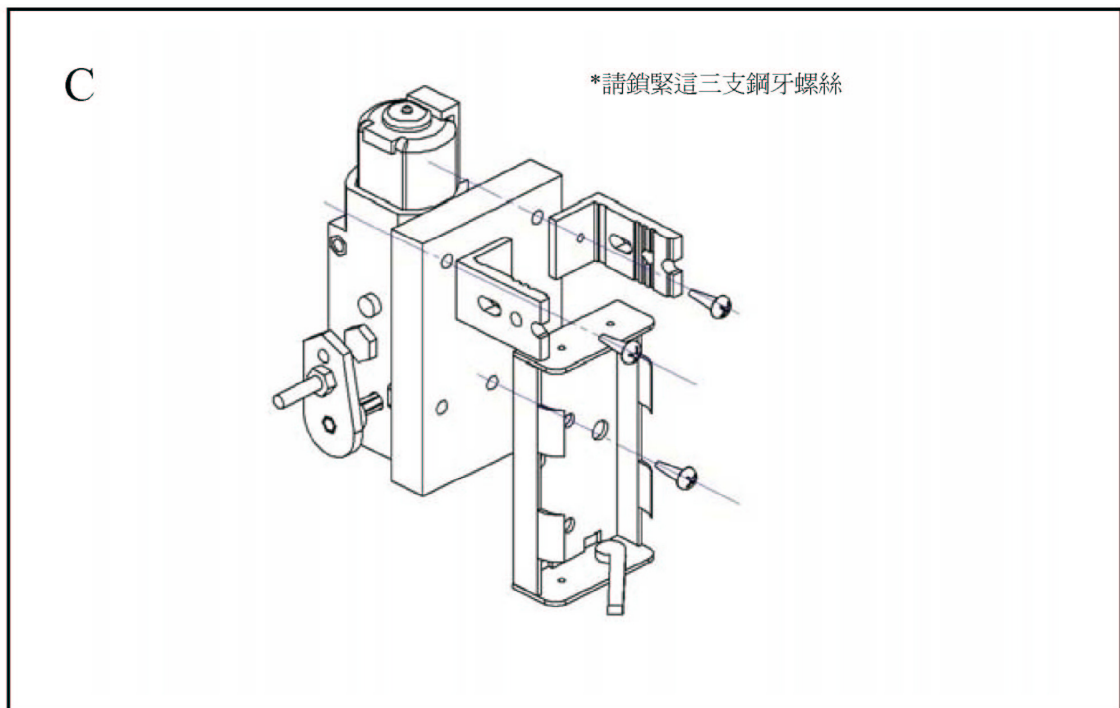
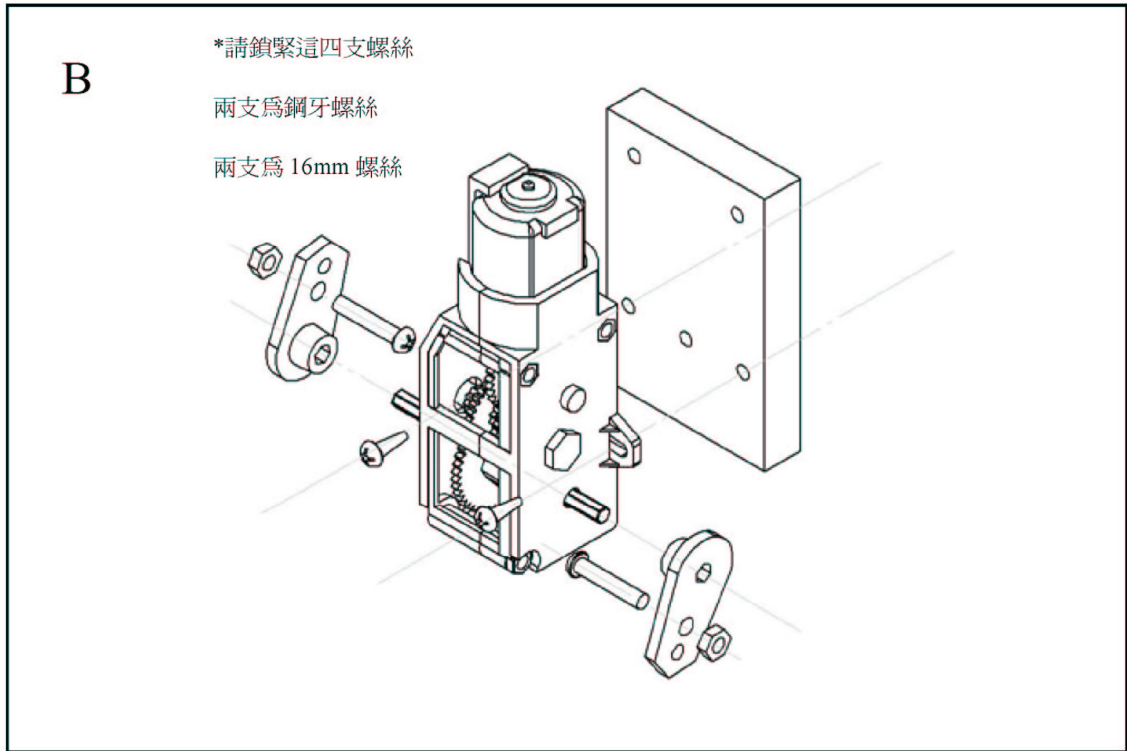

D

*請不要鎖死這兩支螺絲

需要預留活動空間

這兩支為 16mm 螺絲

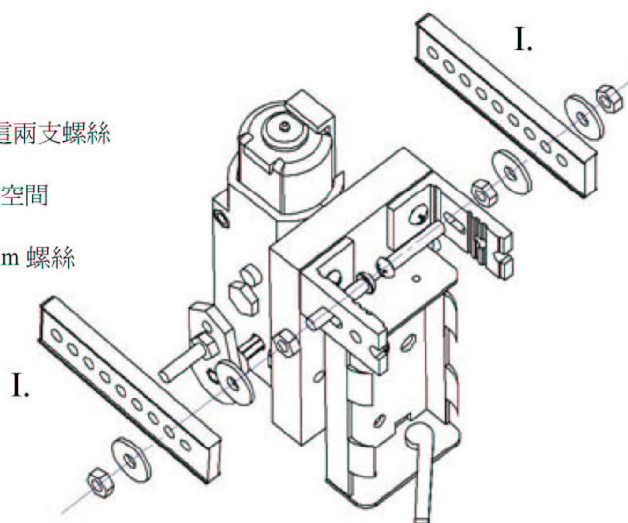

E

*請分別鎖緊三支螺絲

這兩邊兩支為 10mm 螺絲

中間這一支為 12mm 螺絲

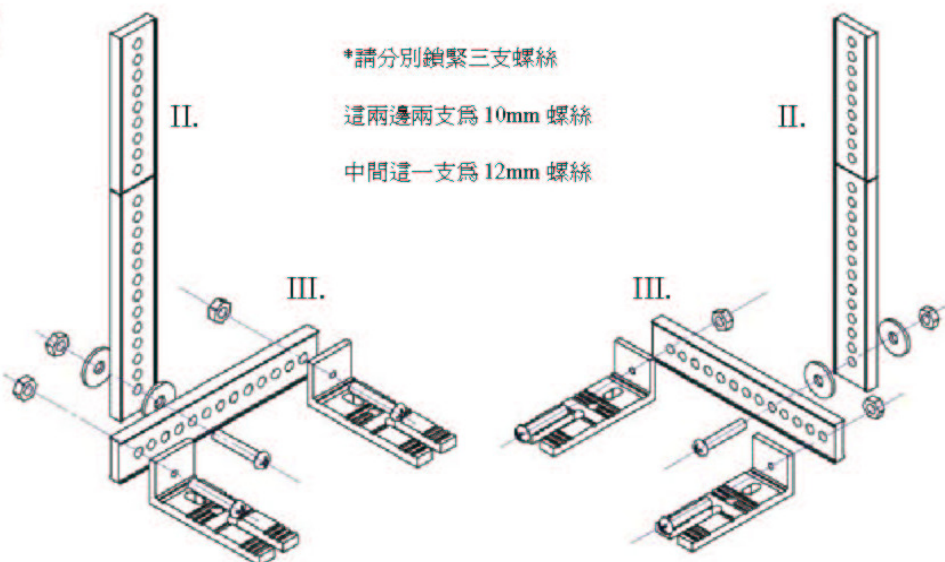

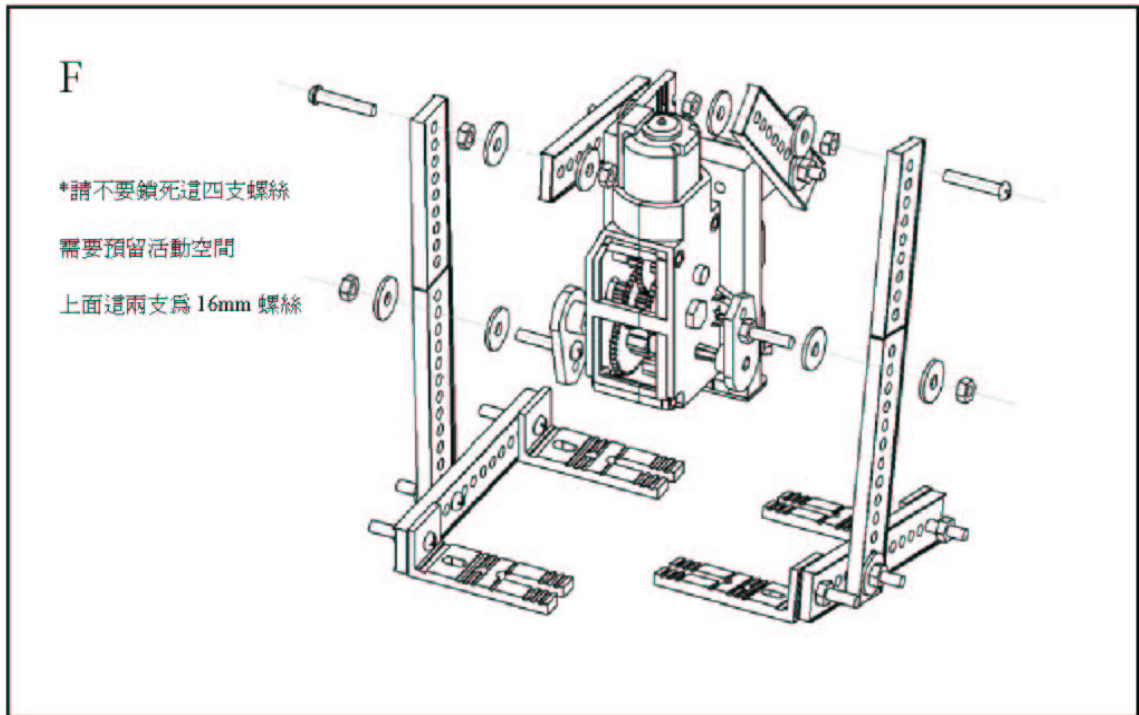

B. NF-06 六速摩打齒輪

請參閱「NF-06 六速摩打齒輪裝配」筆記

